

SLIDING VALVE

3", 4", & 6" VALVE

QUICK OPENING
STAINLESS GATES
BUBBLE TIGHT

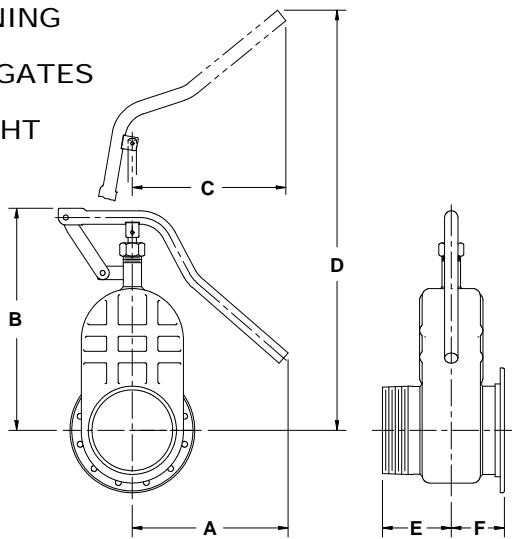

6 in. VALVE SHOWN

The Betts Sliding Valve is an economical means of providing a quick opening – quick closing valve where high working pressure will not be encountered. All valves are standard with stainless steel gates which provide a bubble tight seal.

TTMA DRILLING

Size	Assembly No. Flanged x Flanged	Material	Wt.	Size	Assembly No. Flanged x Threaded	Material	Wt.
3"	SV903 MSM	Steel	11.4	3"	SV913 MSM	Steel	10.9
	SV903 SSM	316 Stainless			SV913 SSM	316 Stainless	
4"	SV904 MSM	Steel	14.9	4"	SV914 MSM	Steel	14.1
	SV904 SSM	316 Stainless			SV914 SSM	316 Stainless	
6"	SV906 MSM	Steel	32.5	6"	SV916 MSM	Steel	30.0
	SV906 SSM	316 Stainless			SV916 SSM	316 Stainless	

ANSI DRILLING *

Size	Assembly No. Flanged x Flanged	Material	Wt.	Size	Assembly No. Flanged x Threaded	Material	Wt.
3"	SV953 MSM	Steel	19.0	3"	SV963 MSM	Steel	15.0
	SV953 SSM	316 Stainless			SV963 SSM	316 Stainless	
4"	SV954 MSM	Steel	24.5	4"	SV964 MSM	Steel	20.0
	SV954 SSM	316 Stainless			SV964 SSM	316 Stainless	
6"	SV956 MSM	Steel	46.0	6"	SV966 MSM	Steel	40.0
	SV956 SSM	316 Stainless			SV966 SSM	316 Stainless	

Dimensions

Size	A	B	C	D	E	F	TTMA Flange				ANSI Flange *				Max. Working Pressure
							O.D.	B.C.	Holes	Thick.	O.D.	B.C.	Holes	Thick.	
3"	9 1/2	11 5/8	9	19	3 3/16	2 1/4 †	6 1/8	4 1/8	8 - 1/16	.1345	7 1/2	6	4 - 3/4	1 1/2	75 PSI
4"	10	13	9	24	3 5/16	2 5/8 *	7 1/8	5 1/8	8 - 1/16	.1345	9	7 1/2	8 - 3/4	1 1/2	75 PSI
6"	8	17	14	26	5 1/16	4	9 3/8	8 1/8	12 - 1/16	.1345	11	9 1/2	8 - 7/8	1 1/2	50 PSI

*ANSI Dimension 3 1/2"

*Drilling Dimensions Only

† 3" ANSI Dimension 2 5/8"

PARTS LIST

SLIDING VALVE

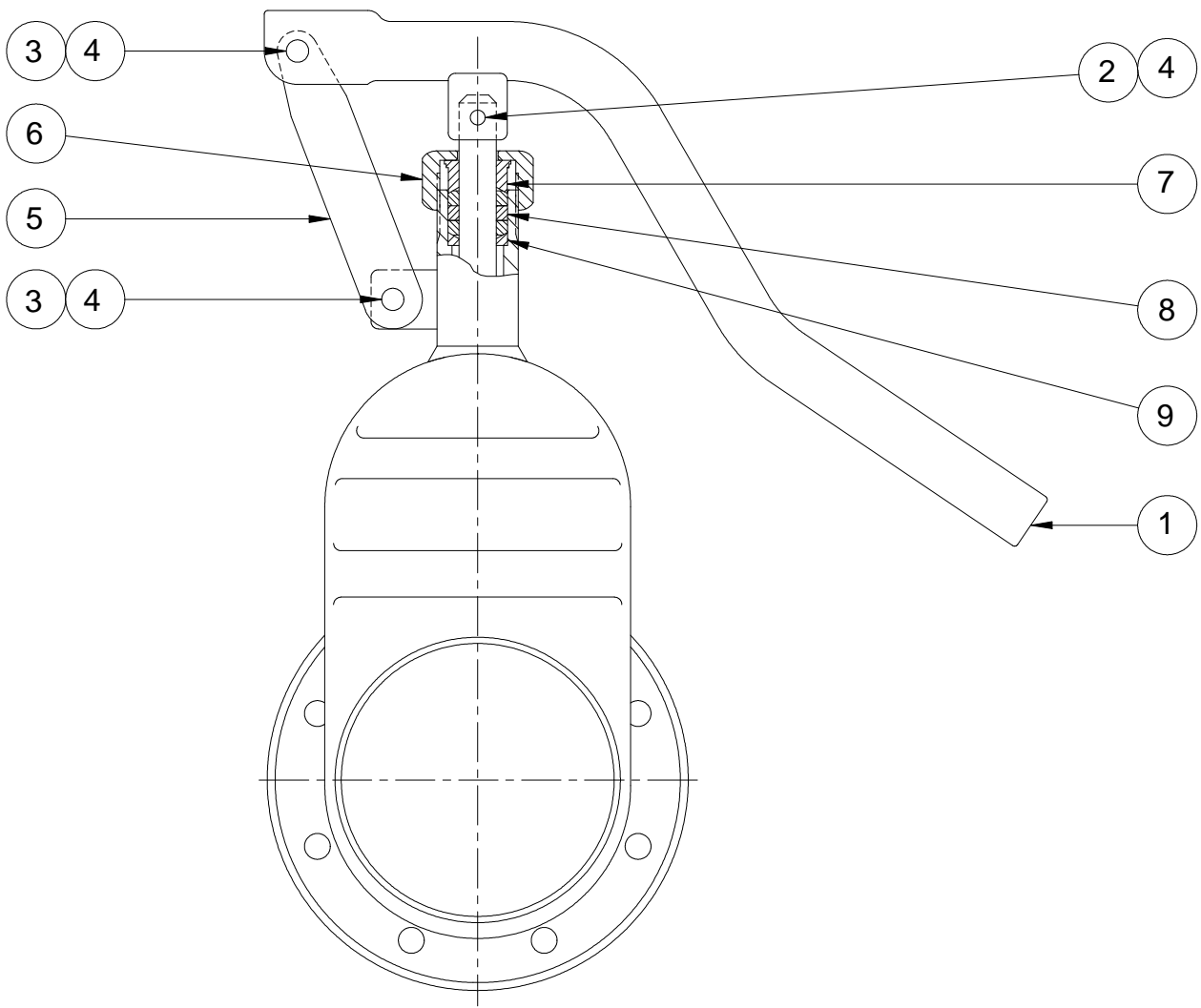

Item No.	Description	Req'd.	Material	3" & 4" Valve Part No.	6" Valve Part No.
1	Handle	1	Steel "E" Coated	35131EY	26764EY
2	Clevis Pin $1/4 \times 1 1/4$	1	Steel Zinc Plt.	9Q4728	9Q4728
3	Clevis Pin-Link	2	Steel "E" Coated	15757EY	15757EY
4	Cotter Pin $3/32 \times 3/4$	3	Brass	9Q5865	9Q5865
5	Link	1	Steel "E" Coated	17446EY	17903EY
6	Stuffing Box Nut	1	Aluminum	15026AL	15026AL
			304 Stainless	16026SL	15026SL
7	Top Gland	1	316 Stainless	15220SS	15220SS
8	Packing	Set	Non-Asbestos/Teflon	15227NT	15227NT
9	Bottom Gland	1	316 Stainless	15076SS	15076SS

WARNING Use only genuine Betts Industries Inc. replacement parts. Use of substitute part can impair the proper functioning of this product.